

SPRINKLER INSTALLATION CONTROL VALVE SETS

Implementation date: It is recommended that this Technical Bulletin should be implemented for all contracts let after <[INSERT DATE] 3 months after publication>

SUPPLEMENTS BS EN CLAUSES 15, 16 AND D.3.6

TB 232.1 SCOPE

This Technical Bulletin specifies the types of alarm valve which may be used and the design of installation control valves. Measures are specified to ensure the continuous supply of water to sprinkler installations whilst alarm valve maintenance is undertaken. Alternate alarm valves have been excluded on the grounds of causing accelerated corrosion to sprinkler pipework.

TB 232.2 DEFINITIONS

TB 232.2.1 Control valve set (BS EN Clause 3.17)

Assembly comprising at least one alarm valve, stop valves and all the associated valves and accessories for the control of one sprinkler installation.

TB 232.3 GENERAL

TB 232.3.1 Nominal size

Stop valves and alarm valves shall be the same nominal diameter as the pipework.

TB 232.3.2 Alarm connections (supplements BS EN Clause 16.1.1)

Each control valve set shall be connected to a water motor alarm complying with BS EN12259-4 and an electrical device for remote alarm indication, both located as close as possible to the alarm valve. A single alarm motor and gong may be common to a group of wet alarm valves providing that they are in the same valve room and an indicator is fitted to each alarm valve to show when it is operating. There shall be a low level alarm line drain in close proximity to the alarm valve(s). The drain shall be arranged so that any flow of water from the drain can be seen.

TB 232.3.3 Monitoring

Control valve set stop valves which are capable of interrupting or controlling the flow of water to sprinklers shall be fitted with tamper-proof devices which monitor their status.

The monitoring devices shall be electrically connected to a control and indicating panel complying with BS EN Clause D.3.7.

TB 232.4 TYPES OF ALARM VALVE

The following types of alarm valve are considered suitable for sprinkler service:

- Alarm valve, dry (BS EN Clause 3.6) ;
- Alarm valve, pre-action (BS EN Clause 3.7);
- Alarm valve, wet (BS EN Clause 3.8) ;

COMMENTARY AND RECOMMENDATIONS ON TB230.4

Alternate alarm valves are no longer considered suitable for sprinkler service due to the potential for accelerating the rate of pipework corrosion and have therefore been excluded from the above list.

TB 232.5 INSTALLATION CONTROL VALVE ARRANGEMENTS

Two main installation control valve arrangements are described in this Technical Bulletin. Either of these two arrangements shall be used for property protection purposes.

COMMENTARY AND RECOMMENDATIONS ON TBTB 232.5

A single installation control valve set will not be permissible for property protection purposes.

TB 232.5.1 Wet pipe installation main control valve with by-pass arrangement

TB 232.5.1.1 General

The installation main control valve set shall have two normally open stop valves one each side (upstream and downstream) of a single wet alarm valve with a bypass connection of the same nominal bore around all three valves. The bypass shall be fitted with a normally closed stop valve, see Figure TB232.F1.

TB 232.5.1.2 Application

The installation main control valve with a by-pass arrangement shall be used for wet pipe installations.

TB 232.5.1.3 Alarm valve maintenance

During maintenance of the wet alarm valve, close stop valves (2) and (4) and open stop valve (5). On completion of maintenance return the stop valves to their normal positions

Figure TB232.F1 Wet pipe installation control valve arrangement with bypass

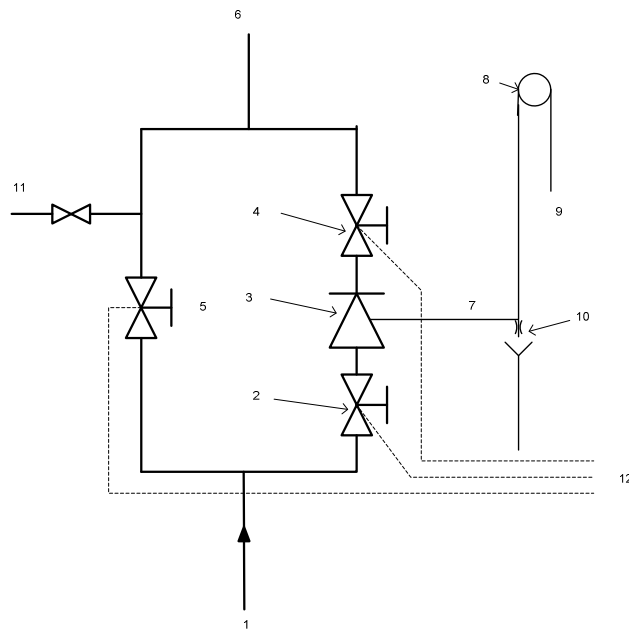

Key

- | | |
|--------------------------------|---|
| 1 Water supply | 7 Alarm line connection |
| 2 Upstream stop valve | 8 Hydraulic alarm gong |
| 3 Installation wet alarm valve | 9 Alarm line flow to waste |
| 4 Downstream stop valve | 10 Alarm line drain with visible out flow |
| 5 Bypass stop valve | 11 Drain |
| 6 Installation | 12 Stop valve monitoring connections |

TB 232.5.2 Duplicate installation main control valve

TB 232.5.2.1 General

A stop valve on each side (i.e. upstream and downstream) of each of a pair of alarm valves; each set of three valves connected in parallel to the feed main, see Figure TB32.F3. One set of three valves shall be designated as the primary installation main control valve set with the upstream and downstream stop valves normally open. The stop valve on the secondary installation valve set shall be normally closed.

TB 232.5.2.2 Application

Duplicate installation control valves shall be used on dry-pipe and pre-action installations or as an alternative arrangement to the installation control valve with a bypass on wet pipe systems

TB 232.5.2.3 Alarm valve maintenance

Before carrying out work on the operational installation control valve set (3a) check the isolated alarm valve set (3b) for condition and fitness for service. Commission the alarm valve set (3b) in accordance with the supplier's instructions and open the upstream (4b) and downstream (2b) stop valves. Open alarm line isolating valve (5b). When the alarm valve (3b) is in service close the upstream (4a) and downstream (2a) stop valve to isolate alarm valve (3a) and alarm line isolating valve (5a). Service the alarm valve (3a) in accordance with the suppliers instructions.

Figure TB232.F2 Duplicate installation control valve arrangement

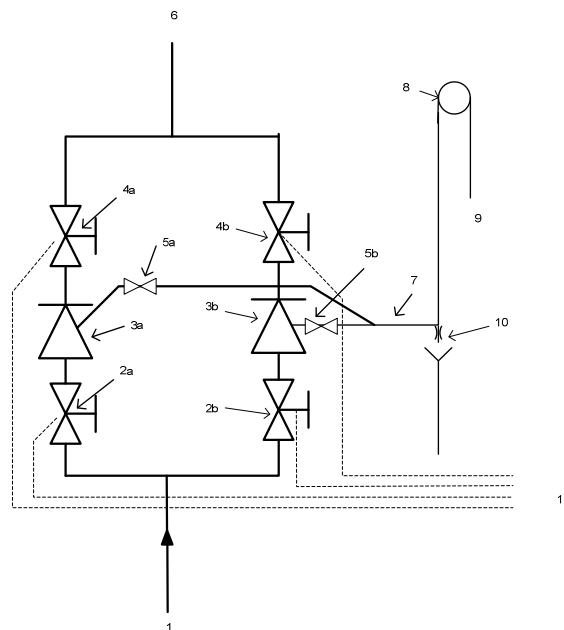

Key

- | | |
|--|---|
| 1 Water supply | 5a Alarm line isolating valve – alarm valve “A” |
| 2a Upstream stop valve – alarm valve “A” | 5b Alarm line isolating valve – alarm valve “B” |
| 2b Upstream stop valve – alarm valve “B” | 6 Installation |
| 3a Installation alarm valve “A” | 7 Alarm line connection |
| 3b Installation alarm valve “B” | 8 Hydraulic alarm gong |
| 4a Downstream stop valve – alarm valve “A” | 9 Alarm line flow to waste |
| 4b Downstream stop valve – alarm valve “B” | 10 Alarm line drain with visible out flow |
| | 11 Stop valve monitoring connections |

TB 232.6 TAIL END DRY AND PRE-ACTION VALVES

TB 232.6.1 Tail end dry pipe valves may be installed in accordance with TB 232.5.1 without the alarm line connections.